

Prolabs SFP-10G-ZR

SFP-10G-ZR Optical Transceiver

Key Features

- Up to 10.7 GBd bi-directional data links
- Compliant with 10GBASE-ZR
- Compliant with 10GFC
- Compliant with SFF-8431
- Hot-pluggable SFP+ footprint
- Temperature-stabilized 1550nm EML laser
- Duplex LC connector
- Built-in digital diagnostic functions
- Up to 80km on SMF
- Single power supply 3.3V
- RoHS Compliance
- Class 1 laser product complies with EN 60825-1
- Operating temperature range: 0°C to 70°C.

Applications

- 10GBASE-ZR Ethernet
- 10GFC



Ordering Information

Part Number	Description
SFP-10G-ZR	10GBASE-ZR SFP+, 1550nm, 80km over SMF. DOM Support.

Introduction

PROLABS's SFP-10G-ZR optical transceivers are based on 10G Ethernet IEEE 802.3ae standards and SFF-8431 MSA, and provide a reliable interface for 10G applications. The Digital diagnostics functions are available via 2-wire serial bus as specified in SFF-8472.

Compatible Ordering Information

OEM Manufacturer	Prolabs Ordering SKU	Product Description
ADVA	1061701812-C	10GBASE-ZR SFP+, 1550nm, 80km
Alcatel	3FE65832AA-C	10GBASE-ZR SFP+, 1550nm, 80km
	SFP-10G-ZR-ALC-C	10GBASE-ZR SFP+, 1550nm, 80km
Allied	AT-SP10ZR80-C	10GBASE-ZR SFP+, 1550nm, 80km
Arista	SFP-10G-ZR-ARISTA-C	10GBASE-ZR SFP+, 1550nm, 80km
Avaya	AA1403013-80KM-C	10GBASE-ZR SFP+, 1550nm, 80km
Brocade	10G-SFPP-ZR-C	10GBASE-ZR SFP+, 1550nm, 80km
BTN/IBM	BN-CKM-SP-ZR-C	10GBASE-ZR SFP+, 1550nm, 80km
Checkpoint	CPAC-TR-10ZR-C	10GBASE-ZR SFP+, 1550nm, 80km
Ciena	XCVR-S80V55-C	10GBASE-ZR SFP+, 1550nm, 80km
Cisco	ONS-SC+-10G-ZR-C	10GBASE-ZR SFP+, 1550nm, 80km
	SFP-10G-ZR-C	10GBASE-ZR SFP+, 1550nm, 80km
	SFP-10G-ZR-S-C	10GBASE-ZR SFP+, 1550nm, 80km
Dell Force10	GP-10GSFP-1Z-C	10GBASE-ZR SFP+, 1550nm, 80km
Enterasys	10GB-ZR-SFPP-C	10GBASE-ZR SFP+, 1550nm, 80km
Extreme	10310-C	10GBASE-ZR SFP+, 1550nm, 80km
Fortinet	FG-TRAN-SFP+ZX-C	10GBASE-ZR SFP+, 1550nm, 80km
Generic	ZR-SFP-10G-C	10GBASE-ZR SFP+, 1550nm, 80km
H3C Huawei	SFP-XG-LH80-SM1550-H3C-C	10GBASE-ZR SFP+, 1550nm, 80km
HP Comware	JG915A-C	10GBASE-ZR SFP+, 1550nm, 80km
HP ProCurve	J9153A-80KM-C	10GBASE-ZR SFP+, 1550nm, 80km
Huawei	LE2MXSC80FF0-C	10GBASE-ZR SFP+, 1550nm, 80km
Juniper	EX-SFP-10GE-ZR-C	10GBASE-ZR SFP+, 1550nm, 80km
Moxa	SFP-10GERLC-80KM-C	10GBASE-ZR SFP+, 1550nm, 80km
MRV	SFP-10GD-ZR-C	10GBASE-ZR SFP+, 1550nm, 80km
Palo Alto	PAN-SFP-PLUS-ZR-C	10GBASE-ZR SFP+, 1550nm, 80km
Riverbed	SFP-CSK-ZR-C	10GBASE-ZR SFP+, 1550nm, 80km
Ruijie	XG-SFP-ZR-SM1550-C	10GBASE-ZR SFP+, 1550nm, 80km
Telco	BTI-10GZR-DD-SFP+-C	10GBASE-ZR SFP+, 1550nm, 80km
Transmode	TRX100115-C	10GBASE-ZR SFP+, 1550nm, 80km
ZTE	SFP-10GE-S80K-C	10GBASE-ZR SFP+, 1550nm, 80km

Specification

General Specifications						
Parameter	Symbol	Min	Typ	Max	Unit	Remarks
Data Rate	DR	-	10.3125	-	GBd	IEEE 802.3ae
Bit Error Rate	BER	-	-	10^{-12}	-	-
Operating Temperature	T _{OP}	0	-	70	°C	Case temperature.
Storage Temperature	T _{STO}	-40	-	85	°C	Ambient temperature.
Supply Current	I _S	-	450	500	mA	For electrical power interface.
Input Voltage	V _{CC}	3	3.3	3.6	V	-
Maximum Voltage	V _{MAX}	-0.5	-	4	V	For electrical power interface.

Link Distances		
Parameter	Fiber Type	Distance Range (Km)
10.3125 GBd	9/125um SMF	80

Optical Characteristics-Transmitter V _{CC} =3V to 3.6V, T _C =0°C to 70°C						
Parameter	Symbol	Min	Typ	Max	Unit	Remarks
Output Optical Power	P _{TX}	0	-	0.5	dBm	Average Power
Optical Center Wavelength	λ _c	1530	-	1565	nm	-
Extinction Ratio	ER	9	-	-	dB	-
Spectral Width (-20dB)	Δλ	-	-	0.6	nm	-
SideMode Suppression Ratio	SMSR	30	-	-	dB	-
Relative Intensity Noise	RIN	-	-	-128	dB/Hz	-
Transmitter Dispersion Penalty	TDP	-	-	3.2	dB	-
Transmitter Jitter	-	-	-	-	-	According to IEEE 802.3 Requirements.
Launch Power of OFF Transmitter	P _{OUT_OFF}	-	-	-30	dBm	Average Power

Specification

Optical Characteristics-Receiver V _{CC} =3V to 3.6V, T _C =0°C to 70°C						
Parameter	Symbol	Min	Typ	Max	Unit	Remarks
Optical Center Wavelength	λ_C	1260	-	1565	nm	-
Optical Input Power	P _{IN}	-24	-	-7	dBm	Average, Informative
Receiver Sensitivity in OMA @ 10.3GBd	R _{X SEN1}	-	-	-24	dBm	Measured with worst ER: BER<10 ⁻¹² 2 ³¹ -1 PRBS
Receiver Reflectance	TR _{RX}	-	-	-27	dB	-
Loss of Signal-Asserted	P _{LOS A}	-30	-	-	dBm	-
Loss of Signal-Deasserted	P _{LOS D}	-	-	-25	dBm	-
Loss of Signal-Hysteresis	-	0.5	-	-	dB	-

Electrical Characteristics-Transmitter V _{CC} =3V to 3.6V, T _C =0°C to 70°C						
Parameter	Symbol	Min	Typ	Max	Unit	Remarks
Input differential impedance	R _{IN}	-	100	-	Ω	-
Single ended data input swing	V _{IN PP}	250	-	800	mV	-
Transmit disable voltage	V _D	2	-	V _{CC}	V	-
Transmit enable voltage	V _{EN}	V _{EE}	-	V _{EE} +0.8	V	-

Electrical Characteristics-Receiver V _{CC} =3V to 3.6V, T _C =0°C to 70°C						
Parameter	Symbol	Min	Typ	Max	Unit	Remarks
Single ended data output swing	V _{OUT PP}	150	300	425	mV	-
Data output rise time (20%-80%)	T _R	-	30	-	ps	-
Data output fall time (20%-80%)	T _F	-	30	-	ps	-
LOS Fault	V _{LOS Fault}	2	-	V _{CC HOST}	V	-
LOS Normal	V _{LOS Normal}	V _{EE}	-	V _{EE} +0.5	V	-

Specification

Digital Diagnostic Functions

The ZR-SFP-10G-C supports the 2-wire serial communication protocol as defined in SFF-8472. Digital diagnostic information is accessible over the 2-wire interface at the address 0xA2. Digital Diagnostics for SFP-ZR-10G are internally calibrated by default. A micro controller unit inside the transceiver gathers the monitoring information and reports the status of transceiver.

Transceiver Temperature,

internally measured, represented as a 16 bit signed twos complement value in increments of 1/256 degrees Celsius, Temperature accuracy is better than ± 3 degrees Celsius over specified operating temperature and voltage.

Transceiver Supply Power,

internally measured, represented as a 16 bit unsigned integer with the voltage defined as the full 16 bit value (0 – 65535) with LSB equal to 100 μ Volt, yielding a total range of 0 to +6.55 Volts.

Transceiver TX bias current,

internally measured, represented as a 16 bit unsigned integer with the current defined as the full 16 bit value (0 – 65535) with LSB equal to 2 μ A, yielding a total range of 0 to 131mA. Accuracy is better than $\pm 10\%$ over specified operating temperature and voltage.

Transceiver TX output power,

internally measured, represented as a 16 bit unsigned integer with the power defined as the full 16 bit value (0 – 65535) with LSB equal to 0.1 μ W. Data is assumed to be based on measurement of laser monitor photodiode current. Accuracy is better than ± 3 dB over specified temperature and voltage. Data is not valid when the transmitter is disabled.

Transceiver RX received optical power,

internally measured, represented as a 16 bit unsigned integer with the power defined as the full 16 bit 35 value (0 – 65535) with LSB equal to 0.1 μ W. Accuracy is better than ± 3 dB over specified temperature and voltage.

Specification

Block Diagram of Transceiver

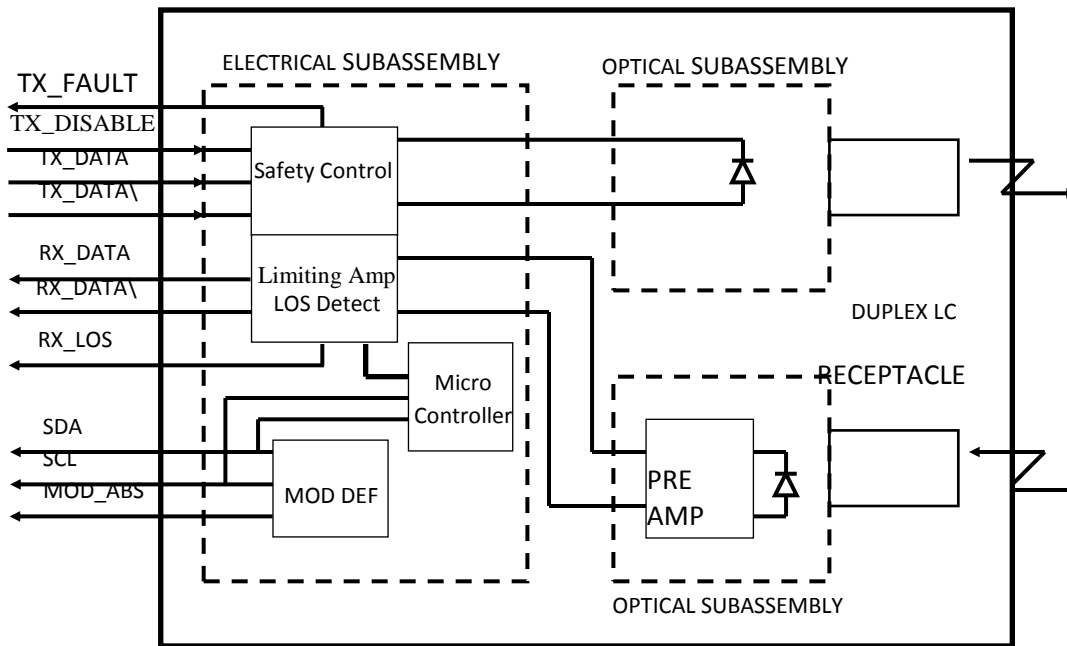

Transmitter Section

The Laser driver accept differential input data and provide bias and modulation currents for driving a laser. An automatic power-control (APC) feedback loop is incorporated to maintain a constant average optical power. The laser is packaged in an eye safe optical subassembly (OSA) which mates to the fiber cable.

TX_DISABLE

The TX_DISABLE signal is high (TTL logic "1") to turn off the laser output. The laser will turn on within 1ms when TX_DISABLE is low (TTL logic "0").

TX_FAULT

When the TX_FAULT signal is high, output indicates a laser fault of some kind. Low indicates normal operation.

Receiver Section

The receiver utilizes a PIN detector integrated with a trans-impedance preamplifier in an OSA. This OSA is connected to a Limiting Amplifier which providing post-amplification quantization, and optical signal detection. The limiting Amplifier is AC-coupled to the trans impedance amplifier, with internal 100Ω differential termination.

Receive Loss (RX_LOS)

The RX_LOS is high (logic "1") when there is no incoming light from the companion transceiver. This signal is normally used by the system for the diagnostic purpose. The signal is operated in TTL level.

Controller Section

The micro controller unit monitors the operation information of LD driver and Limiting Amplifier. And report these statuses to the customer.

Dimensions

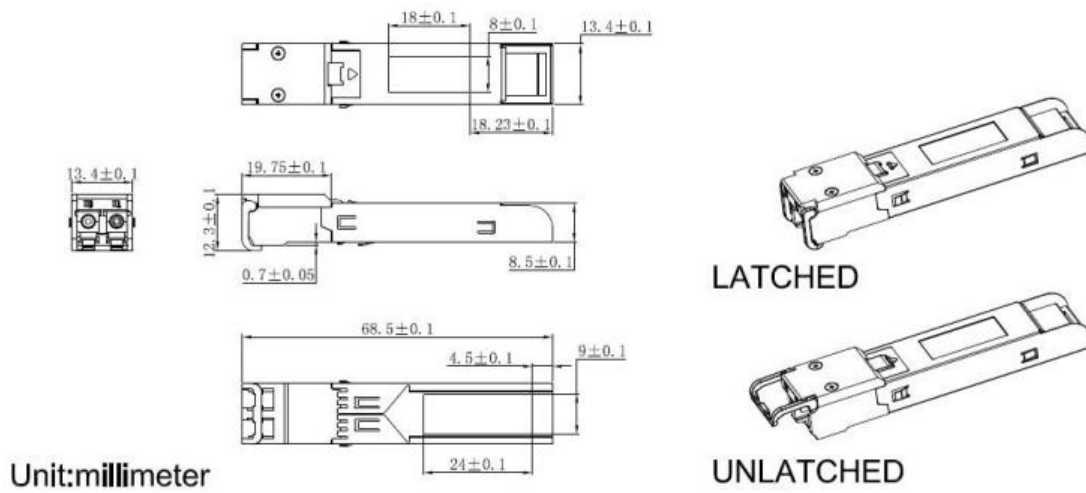

**ALL DIMENSIONS ARE ± 0.2 mm UNLESS OTHERWISE SPECIFIED
UNIT: mm**

PCB Layout Recommendations

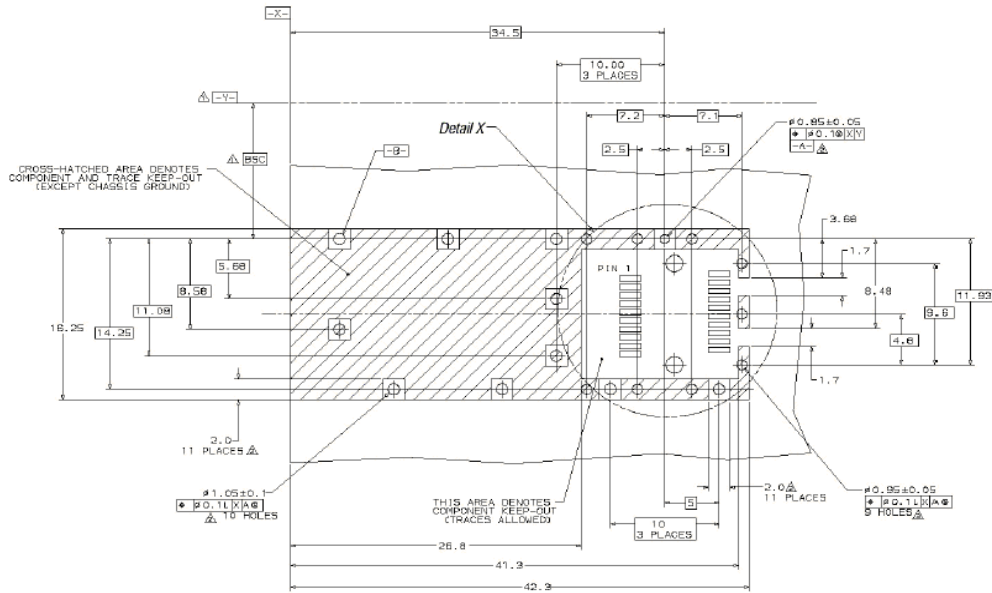

Datum and Basic Dimension Established by Customer
 Rads and Vias are Chassis Ground, 11 Places
 Through Holes are Unplated

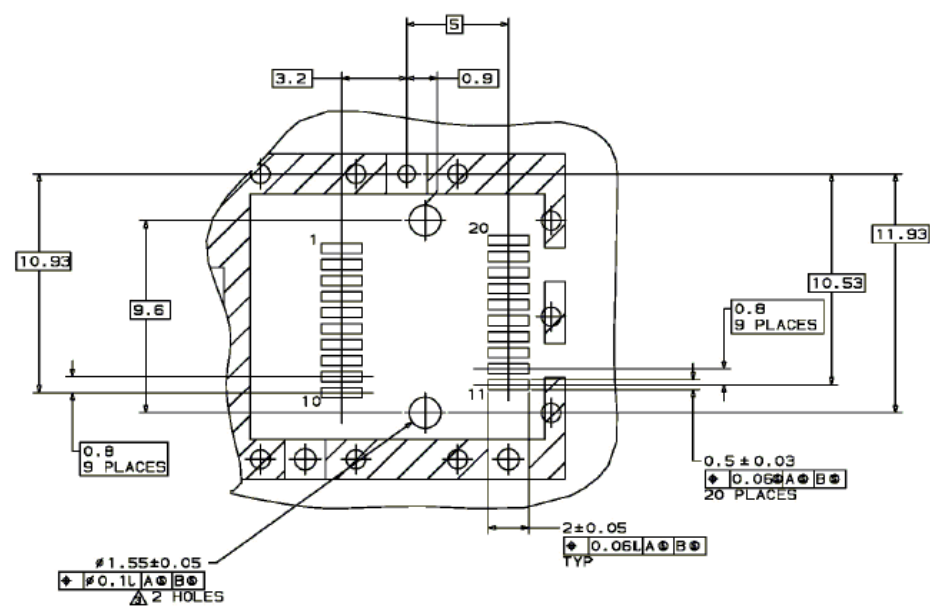

Electrical Pad Layout

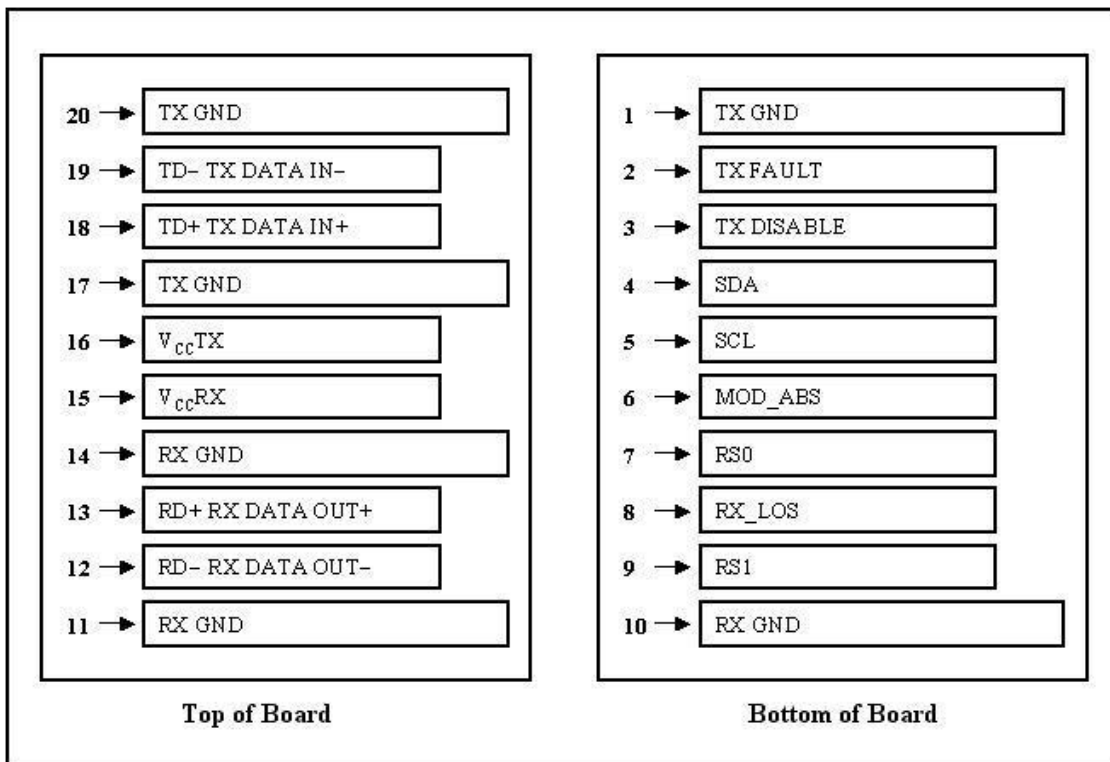
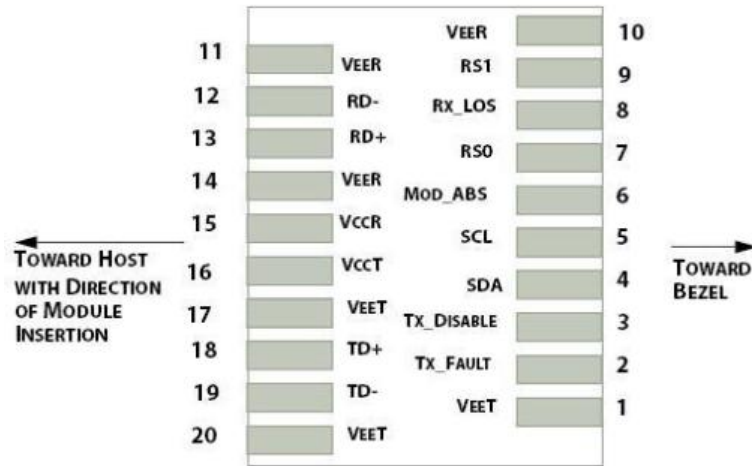

Pin Assignments

Pin Assignments			
Pin #	Symbol	Description	Remarks
1	V _{EET}	Transmitter ground (common with receiver ground)	Circuit ground is isolated from chassis ground
2	T _{FAULT}	Transmitter Fault.	-
3	T _{DIS}	Transmitter Disable. Laser output disable on high or open	Disabled: T _{DIS} >2V or open Enabled: T _{DIS} <0.8V
4	SDA	Data line for serial ID	Should Be pulled up with 4.7k – 10k ohm on host board to a voltage between 2V and 3.6V
5	SCL	Clock line for serial ID	
6	MOD_ABS	Module Absent. Grounded within the module	
7	RS0	No connection required	-
8	LOS	Loss of Signal indication. Logic 0 indicates normal operation	LOS is open collector output
9	RS1	No Connection Required.	Circuit ground is isolated from chassis ground
10	V _{EER}	Receiver ground (common with transmitter ground)	
11	V _{EER}	Receiver ground (common with transmitter ground)	
12	RD-	Receiver Inverted DATA out. AC coupled	-
13	RD+	Receiver Non-inverted DATA out. AC coupled	-
14	V _{EER}	Receiver ground (common with transmitter ground)	Circuit ground is isolated from chassis ground
15	V _{CCR}	Receiver power supply	-
16	V _{CCT}	Transmitter power supply	-
17	V _{EET}	Transmitter ground (common with receiver ground)	Circuit ground is connected to chassis ground
18	TD+	Transmitter Non-Inverted DATA in. AC coupled	-
19	TD-	Transmitter Inverted DATA in. AC coupled	-
20	V _{EET}	Transmitter ground (common with receiver ground)	Circuit ground is connected to chassis ground

References

1. IEEE standard 802.3ae. IEEE Standard Department, 2005.
2. Enhanced 8.5 and 10 Gigabit Small Form Factor Pluggable Module “SFP+” – SFF-8431
3. Digital Diagnostics Monitoring Interface for Optical Transceivers – SFF-8472.