

Prolabs SFP-10G-ER

10Gb SFP+ ER Transceiver

Key Features

- Up to 10.7 GBd bi-directional data links
- Compliant with IEEE 802.3ae 10GBASE-ER/EW
- Compliant with 10GFC
- Compliant with SFF8431
- Hot-pluggable SFP+ footprint
- 1550nm DFB laser transmitter
- Duplex LC connector
- Built-in digital diagnostic functions
- 40km on SMF
- Single power supply 3.3V
- RoHS Compliance
- Operating temperature range: 0°C to 70°C.

Applications

- 10GBASE-ER/EW Ethernet
- 10G Fiber Channel

Ordering Information

Part number	Description
SFP-10G-ER	10GBASE-ER SFP+, 1550nm, 40km over SMF. DOM Support

Introduction

PROLABS's SFP-10G-ER SFP+ optical transceivers are based on 10 G Ethernet IEEE 802.3ae standards and SFF 8431 standard, and provide a quick and reliable interface for the 10G Ethernet application. The Digital diagnostics functions are available via 2-wire serial bus specified in the SFF 8472.

Ordering Information

OEM Manufacturer	Prolabs SKU	Product Description
ADVA	1061701861-01-C	10GBASE-ER SFP+, 1550nm, 40km
Alcatel	3FE65831AA-C	10GBASE-ER SFP+, 1550nm, 40km
	3HE05036AA-C	10GBASE-ER SFP+, 1550nm, 40km
	SFP-10G-ER-ALC-C	10GBASE-ER SFP+, 1550nm, 40km
Allied	AT-SP10ER40-C	10GBASE-ER SFP+, 1550nm, 40km
Arista	SFP-10G-ER-ARISTA-C	10GBASE-ER SFP+, 1550nm, 40km
Avaya	AA1403013-C	10GBASE-ER SFP+, 1550nm, 40km
Brocade	10G-SFPP-ER-C	10GBASE-ER SFP+, 1550nm, 40km
BTN/IBM	90Y9415-C	10GBASE-ER SFP+, 1550nm, 40km
	BN-CKM-SP-ER-C	10GBASE-ER SFP+, 1550nm, 40km
Calix	100-01511-C	10GBASE-ER SFP+, 1550nm, 40km
Checkpoint	CPAC-TR-10ER-C	10GBASE-ER SFP+, 1550nm, 40km
Ciena	XCVR-S40V55-C	10GBASE-ER SFP+, 1550nm, 40km
Cisco	ONS-SC+-10G-ER-C	10GBASE-ER SFP+, 1550nm, 40km
	SFP-10G-ER-C	10GBASE-ER SFP+, 1550nm, 40km
	SFP-10G-ER-S-C	10GBASE-ER SFP+, 1550nm, 40km
Dell Force10	GP-10GSFP-1E-C	10GBASE-ER SFP+, 1550nm, 40km
Enterasys	10GB-ER-SFPP-C	10GBASE-ER SFP+, 1550nm, 40km
Extreme	10309-C	10GBASE-ER SFP+, 1550nm, 40km
Fortinet	FG-TRAN-SFP+EX-C	10GBASE-ER SFP+, 1550nm, 40km
Generic	ER-SFP-10G-C	10GBASE-ER SFP+, 1550nm, 40km
H3C Huawei	SFP-XG-LH40-SM1550-H3C-C	10GBASE-ER SFP+, 1550nm, 40km
HP Comware	JG234A-C	10GBASE-ER SFP+, 1550nm, 40km
HP ProCurve	J9153A-C	10GBASE-ER SFP+, 1550nm, 40km
Huawei	OSX040N01-C	10GBASE-ER SFP+, 1550nm, 40km
Juniper	EX-SFP-10GE-ER-C	10GBASE-ER SFP+, 1550nm, 40km
Marconi	SU69CC-C	10GBASE-ER SFP+, 1550nm, 40km
Moxa	SFP-10GERLC-C	10GBASE-ER SFP+, 1550nm, 40km
MRV	SFP-10GD-ER-C	10GBASE-ER SFP+, 1550nm, 40km
Palo Alto	PAN-SFP-PLUS-ER-C	10GBASE-ER SFP+, 1550nm, 40km
Riverbed	SFP-CSK-ER-C	10GBASE-ER SFP+, 1550nm, 40km
Ruijie	XG-SFP-ER-SM1550-C	10GBASE-ER SFP+, 1550nm, 40km
Telco	BTI-10GER-DD-SFP+-C	10GBASE-ER SFP+, 1550nm, 40km
Transmode	TRX100114-C	10GBASE-ER SFP+, 1550nm, 40km
ZTE	SFP-10GE-S40K-C	10GBASE-ER SFP+, 1550nm, 40km

Specifications

General Specifications

Parameter	Symbol	Min	Typ	Max	Unit	Remarks
Data Rate	DR		10.3125		GBd	IEEE 802.3ae
Bit Error Rate	BER			10^{-12}		
Operating Temperature	T_{OP}	0		70	°C	Case temperature
Storage Temperature	T_{STO}	- 40		85	°C	Ambient temperature
Supply Current	I_S		400	450	mA	For electrical power interface
Input Voltage	V_{CC}	3	3.3	3.6	V	
Maximum Voltage	V_{MAX}	- 0.5		4	V	For electrical power interface

Link Distances

Parameter	Fiber Type	Distance Range (Km)
10.3125 GBd	9/125um SMF	40

Optical Characteristics – Transmitter

$V_{CC}=3V$ to $3.6V$, $T_C=0^{\circ}C$ to $70^{\circ}C$

Parameter	Symbol	Min	Typ	Max	Unit	Remarks
Output Optical Power	P_{TX}	- 5		3	dBm	Average
Optical Center Wavelength	λ_C	1530		1580	nm	
Optical Modulation Amplitude	OMA	- 5.2				Per IEEE 802.3ae
Extinction Ratio	ER	3	6		dB	
Spectral Width (- 20 dB)	$\Delta\lambda$			0.6	nm	
Side Mode Suppression Ratio	SMSR	30			dB	
Relative Intensity Noise	RIN			- 128	dB/Hz	
Transmitter Dispersion Penalty	TDP			3.2	dB	
Transmitter Jitter	According to IEEE 802.3ae requirement					
Launch Power of OFF Transmitter	P_{OUT_OFF}			- 30	dBm	Average

Optical Characteristics – Receiver

$V_{CC}=3V$ to $3.6V$, $T_C=0^{\circ}C$ to $70^{\circ}C$

Parameter	Symbol	Min	Typ	Max	Unit	Remarks
Optical Center Wavelength	λ_C	1260		1600	nm	
Optical Input Power	P_{IN}	- 16		0.5	dBm	Average, Informative
Receiver Sensitivity (OMA)@ 10.3GBd	R_{X_SEN1}			- 14.1	dBm	Measured with worst ER: BER< 10^{-12} 2 ³¹ -1 PRBS
Stressed Receiver Sensitivity in OMA @ 10.3Gb/s	P_{SENS2}			- 11.3	dBm	IEEE 802.3ae
Receiver Reflectance	TR_{RX}			- 27	dB	
LOS Assert	LOS_A	- 25			dBm	
LOS De-Assert	LOS_D			- 18	dBm	
LOS Hysteresis		0.5			dB	

Specifications

Electrical Characteristics – Transmitter

$V_{CC}=3V$ to $3.6V$, $T_C=0^{\circ}C$ to $70^{\circ}C$

Parameter	Symbol	Min	Typ	Max	Unit	Remarks
Input differential impedance	R_{IN}		100		Ω	Non condensing
Single ended data input swing	V_{IN_PP}	250		800	mV	
Transmit disable voltage	V_D	2		V_{CC}	V	
Transmit enable voltage	V_{EN}	V_{EE}		$V_{EE}+0.8$	V	

Electrical Characteristics – Receiver

$V_{CC}=3V$ to $3.6V$, $T_C=0^{\circ}C$ to $70^{\circ}C$

Parameter	Symbol	Min	Typ	Max	Unit	Remarks
Single ended data output swing	V_{OUT_PP}	150	300	425	mV	
Data output rise time (20%-80%)	T_R		30		ps	
Data output fall time (20%-80%)	T_F		30		ps	
LOS Fault	V_{LOS_Fault}	2		$V_{CC_HO_ST}$	V	
LOS Normal	V_{LOS_normal}	V_{EE}		$V_{EE}+0.5$	V	

Digital Diagnostic Functions

SFP-10G-ER supports the 2-wire serial communication protocol as defined in the SFF 8472. Digital diagnostic information are accessible over the 2-wire interface at the address 0xA2. Digital Diagnostics for SFP-10G-ER-C are internally calibrated by default. A micro controller unit inside the transceiver gathers the monitoring information and reports the status of transceiver.

Transceiver Temperature, internally measured, represented as a 16 bit signed twos complement value in increments of 1/256 degrees Celsius, Temperature accuracy is better than ± 3 degrees Celsius over specified operating temperature and voltage.

Transceiver Supply Power, internally measured, represented as a 16 bit unsigned integer with the voltage defined as the full 16 bit value (0 – 65535) with LSB equal to 100 μ Volt, yielding a total range of 0 to +6.55 Volts.

Transceiver TX bias current, internally measured, represented as a 16 bit unsigned integer with the current defined as the full 16 bit value (0 – 65535) with LSB equal to 2 μ A, yielding a total range of 0 to 131mA. Accuracy is better than $\pm 10\%$ over specified operating temperature and voltage.

Transceiver TX output power, internally measured, represented as a 16 bit unsigned integer with the power defined as the full 16 bit value (0 – 65535) with LSB equal to 0.1 μ W. Data is assumed to be based on measurement of laser monitor photodiode current. Accuracy is better than ± 3 dB over specified temperature and voltage. Data is not valid when the transmitter is disabled.

Transceiver RX received optical power, internally measured, represented as a 16 bit unsigned integer with the power defined as the full 16 bit 35 value (0 – 65535) with LSB equal to 0.1 μ W. Accuracy is better than ± 3 dB over specified temperature and voltage.

Specifications

Block Diagram of Transceiver

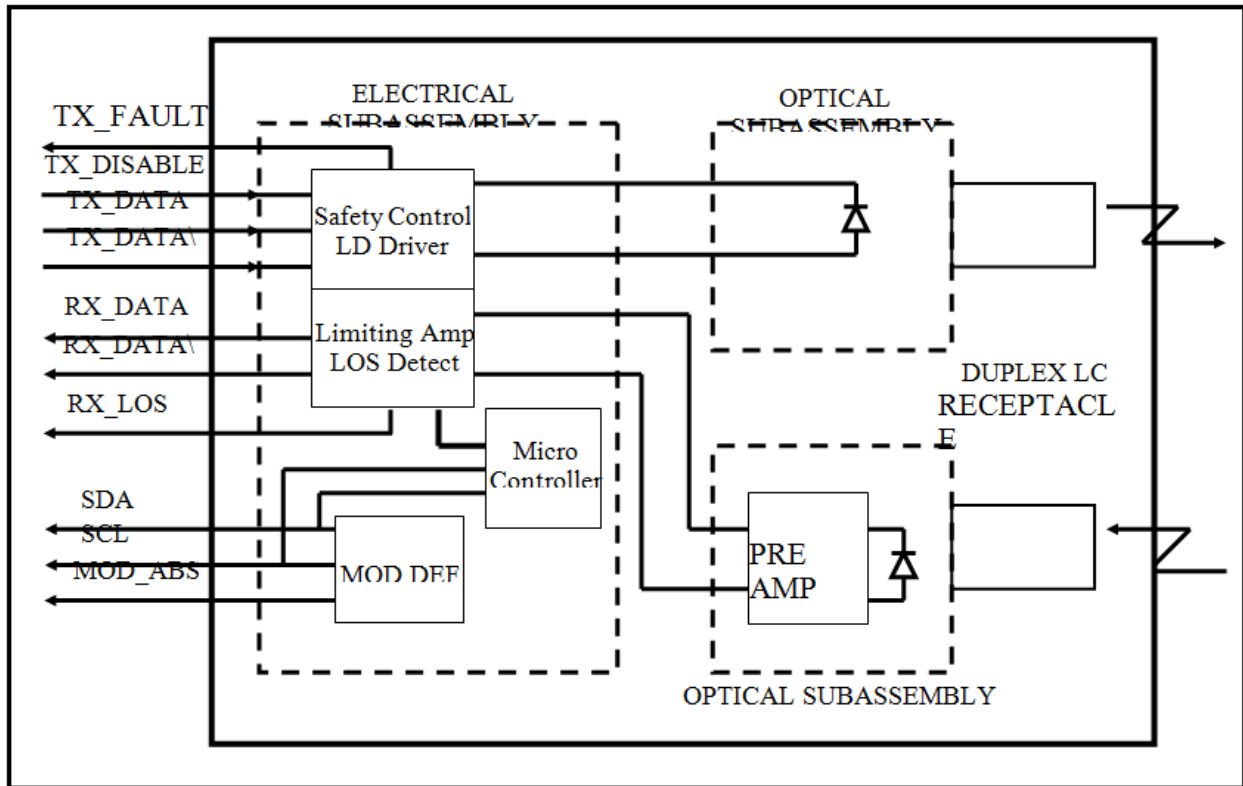

Transmitter Section

The Laser driver accept differential input data and provide bias and modulation currents for driving a laser. An automatic power-control (APC) feedback loop is incorporated to maintain a constant average optical power. 1550 DFB in an eye safe optical subassembly (OSA) mates to the fiber cable.

TX_DISABLE

The TX_DISABLE signal is high (TTL logic "1") to turn off the laser output. The laser will turn on within 1ms when TX_DISABLE is low (TTL logic "0").

TX_FAULT

When the TX_FAULT signal is high, output indicates a laser fault of some kind. Low indicates normal operation.

Receiver Section

The receiver utilizes a PIN detector integrated with a trans-impedance preamplifier in an OSA. This OSA is connected to a Limiting Amplifier which providing post-amplification quantization, and optical signal detection. The limiting Amplifier is AC-coupled to the transimpedance amplifier, with internal 100Ω differential termination.

Receive Loss (RX_LOS)

The RX_LOS is high (logic "1") when there is no incoming light from the companion transceiver. This signal is normally used by the system for the diagnostic purpose. The signal is operated in TTL level.

Controller Section

The micro controller unit monitors the operation information of LD driver and Limiting Amplifier. And report these status to the customer.

Specifications

Dimensions

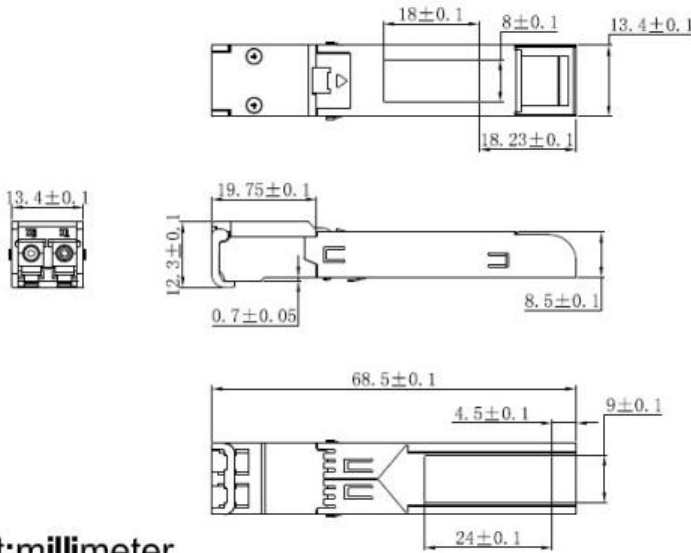

Unit: millimeter

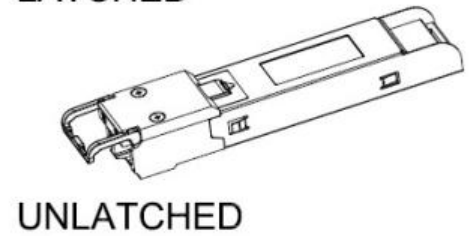
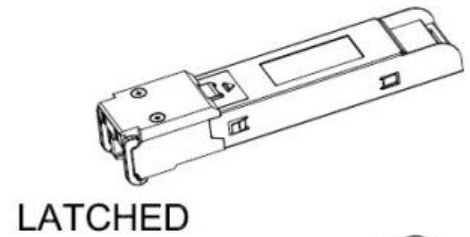



**ALL DIMENSIONS ARE ±0.2mm UNLESS OTHERWISE SPECIFIED
UNIT: mm**

Specifications

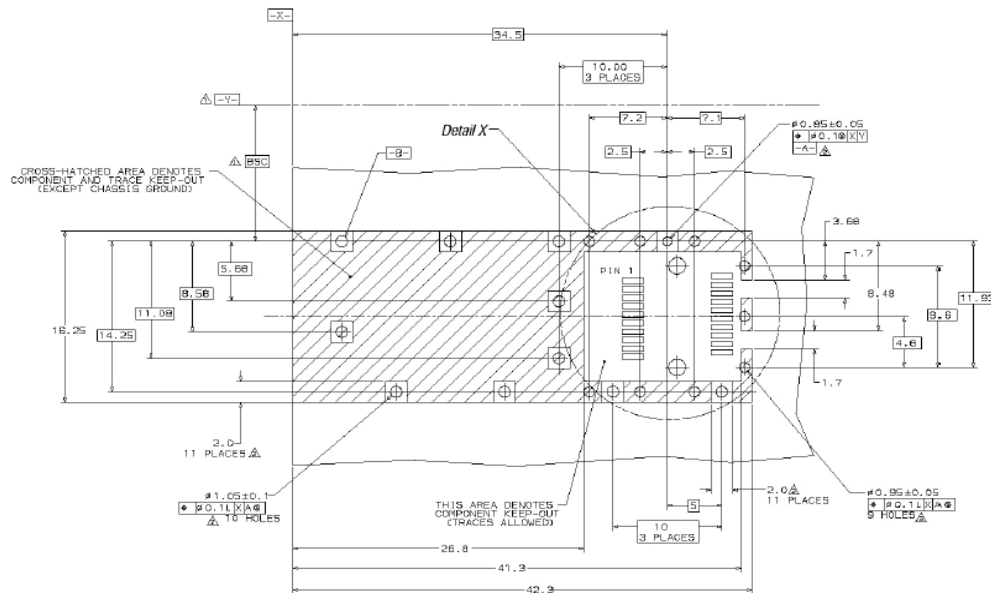
PCB Layout Recommendation



-  Datum and Basic Dimension Established by Customer
-  Pads and Vias are Chassis Ground, 11 Places
-  Through Holes are Unplated

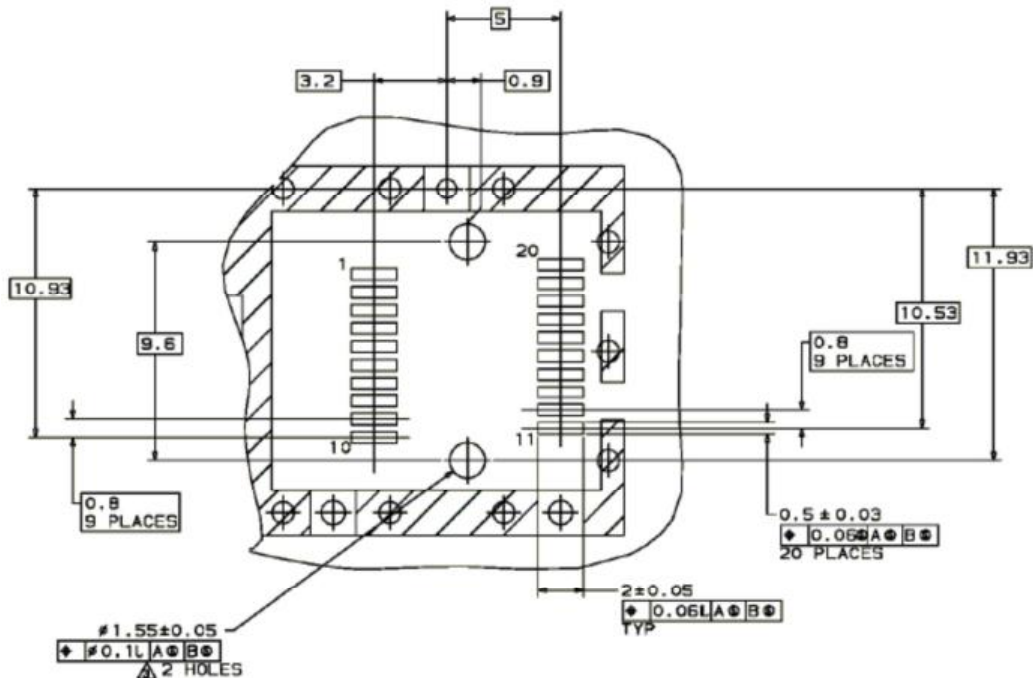

Specifications

Electrical Pad Layout

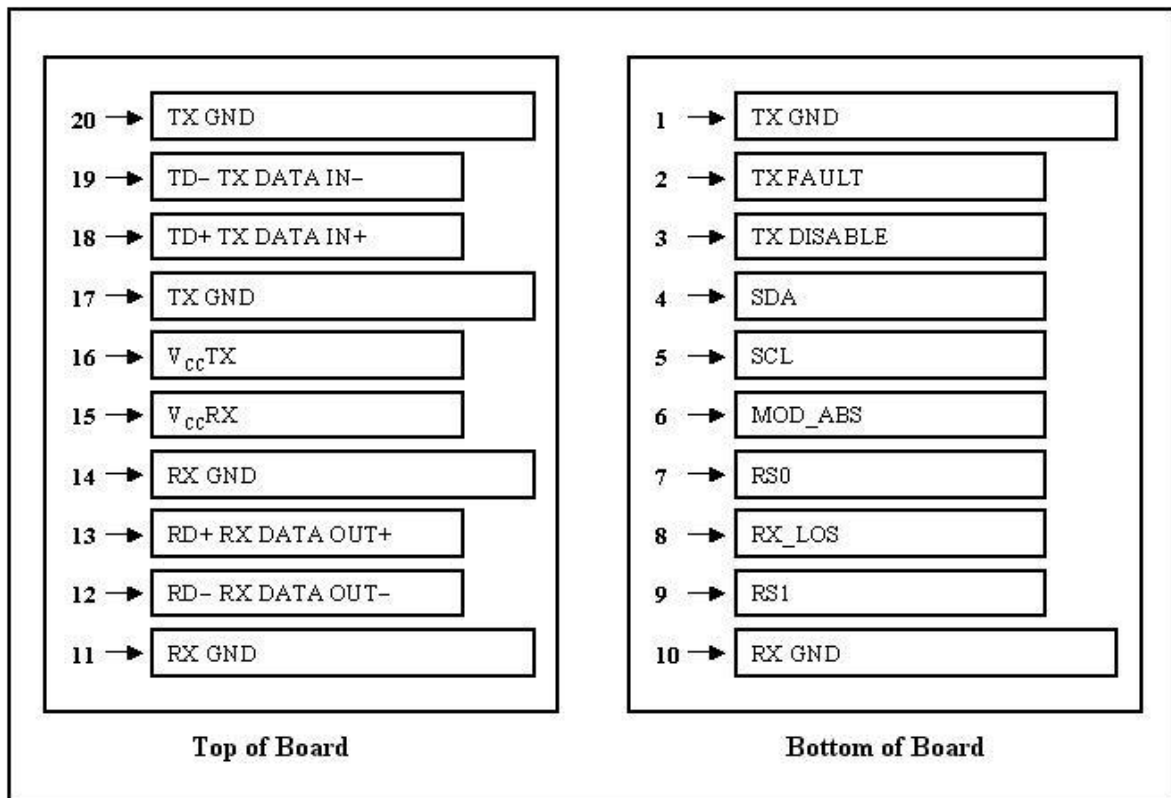
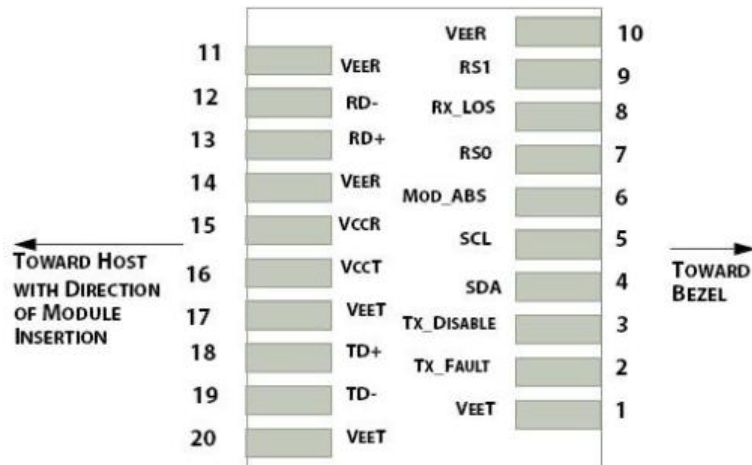

Specifications

Pin Assignment

<i>PIN #</i>	<i>Symbol</i>	<i>Description</i>	<i>Remarks</i>
1	V _{EET}	Transmitter ground (common with receiver ground)	Circuit ground is isolated from chassis ground
2	T _{FAULT}	Transmitter Fault.	
3	T _{DIS}	Transmitter Disable. Laser output disable on high or open	Disabled: T _{DIS} >2V or open Enabled: T _{DIS} <0.8V
4	SDA	Data line for serial ID	Should Be pulled up with 4.7k – 10k ohm on host board to a voltage between 2V and 3.6V
5	SCL	Clock line for serial ID	
6	MOD_ABS	Module Absent. Grounded within the module	
7	RS0	No connection required	
8	LOS	Loss of Signal indication. Logic 0 indicates normal operation	LOS is open collector output
9	RS1	No connection required	Circuit ground is isolated from chassis ground
10	V _{EER}	Receiver ground (common with transmitter ground)	
11	V _{EER}	Receiver ground (common with transmitter ground)	
12	RD-	Receiver Inverted DATA out. AC coupled	
13	RD+	Receiver Non-inverted DATA out. AC coupled	
14	V _{EER}	Receiver ground (common with transmitter ground)	Circuit ground is isolated from chassis ground
15	V _{CCR}	Receiver power supply	
16	V _{CCT}	Transmitter power supply	
17	V _{EET}	Transmitter ground (common with receiver ground)	Circuit ground is connected to chassis ground
18	TD+	Transmitter Non-Inverted DATA in. AC coupled	
19	TD-	Transmitter Inverted DATA in. AC coupled	
20	V _{EET}	Transmitter ground (common with receiver ground)	Circuit ground is connected to chassis ground

References

1. IEEE standard 802.3ae. IEEE Standard Department, 2005.
2. Enhanced 8.5 and 10 Gigabit Small Form Factor Pluggable Module "SFP+" – SFF-8431
3. Digital Diagnostics Monitoring Interface for Optical Transceivers – SFF-8472.